

Solenoid Operated Micro-Pumps

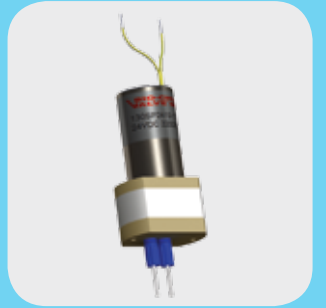

130SP Series Micro-Pump



INDEX

Page 3	Micro-Pump Applications Waste effluent removal, chemical dosing, pumping of sterilizing solution	
Page 4	Micro-Pump Selection Guide	
Page 5	120SP Series Micro-Pump Ported Micro-Pumps (1/4"-28 UNF) for precise dispense volumes from 20 to 60µl
Page 7	130SP Series Micro-Pump Ported Micro-Pumps (1/4"-28 UNF) for precise dispense volumes from 20 to 60µl (inert body)
Page 9	150SP Series Micro-Pump Ported Micro-Pumps (5/16"-24 UNF) for precise dispense volumes from 100 to 250µl
Page 11	139SP Series Micro-Pump Manifold mounted Micro-Pumps for precise dispense volumes from 20 to 60µl
Page 13	Manifolds and Mounting Options	
Page 14	Micro-Pumps Tech Tips - operation and installation	

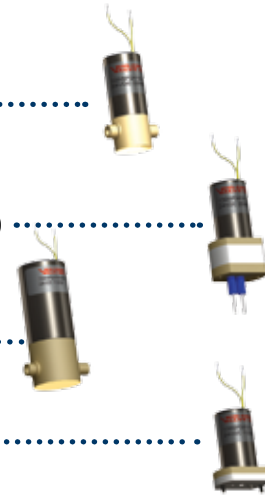

MICRO-PUMPS GENERAL INFORMATION

What is a Micro-Pump?

A Micro-Pump is a solenoid operated device designed to provide a precise, repeatable and discrete dispensed volume of fluid. The

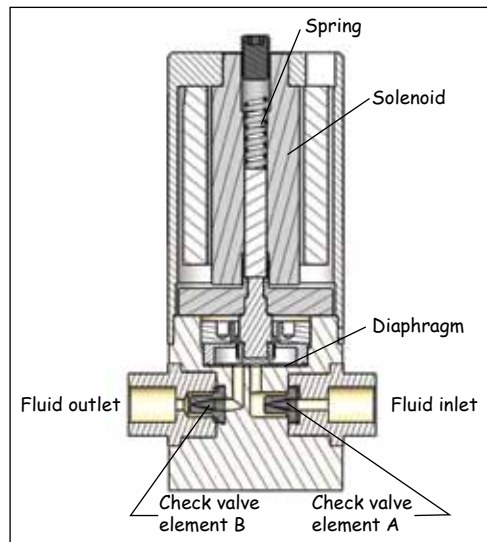

flow path is isolated from the operating mechanism by a flexible diaphragm. When the solenoid is energized, the diaphragm is retracted creating a partial vacuum within the pump body. This pulls liquid through the inlet check valve (A) and simultaneously closes the outlet check valve (B). When the

solenoid is de-energized a spring pushes the diaphragm down, expelling a discrete volume of liquid through check valve B while simultaneously closing check valve A. Micro-Pumps require a complete on-off cycle for each discrete dispense. Repeatedly cycling the solenoid creates a pulsed flow (refer to "Accurate discrete dispense volumes" in next column).

Features of the Bio-Chem Valve™ Micro-Pump

Inert materials

Our pumps provide a non-metallic inert fluid path for the dispensing of high purity or aggressive fluids. There is a range of different materials available for all the wetted parts of the pumps - body, diaphragm and check valve. Material combinations can be chosen to suit the application (refer to individual product selection pages for standard combinations - custom combinations are available, refer to page 14).

Body materials: PPS, PTFE, PEEK™, POM

Diaphragm materials: EPDM, PTFE

Check valve materials: EPDM, FKM, FFKM

Self-priming

At start-up, pumps are able to draw air. The suction created by the pumps is sufficient to pull liquids from an unpressurized container located up to 4' 3" (1.3m) beneath the pump. Once the pump is primed, it is able to generate around 5psi (0.3bar) pressure, equating to 11' 6" (3.5m) of water.

Continuous duty

The pumps are capable of continuous duty at a 2 Hz cycle rate.

Accurate discrete dispense volumes

Dispense volumes range from 20µl to 250µl per cycle. The pumps can be cycled at up to 2 Hz for the smallest version and 1.6 Hz for the largest. Pumps can be operated at less than the maximum cycle rate by increasing the length of the "off" time. The "on" time should remain unchanged to retain dispense accuracy.

Micro-Pump Applications

Waste effluent removal

Many types of analytical instruments incorporate a waste sump or container that collects any liquids that may have leaked inside the instrument. These waste streams can have many constituents and could be regarded as a biohazard if allowed to collect in the bottom of the instrument.

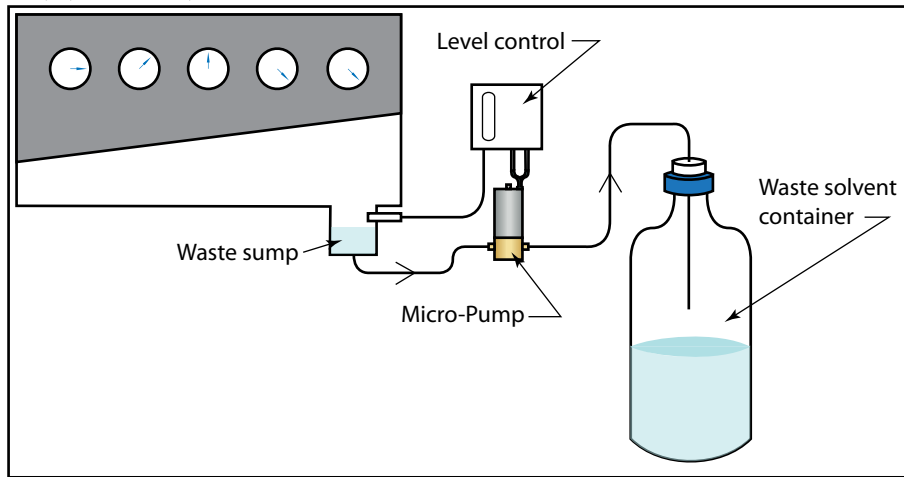

Bio-Chem Fluidics Micro-Pumps lend themselves to this application because they offer a completely inert flow path capable of handling the most aggressive of effluents, while maintaining repeatable and consistent pumping rates.

A Micro-Pump can be hooked up to the level control sensor and be cycled as necessary to empty the sump to an external waste solvent container.

Chemical dosing

In this application Bio-Chem Fluidics Micro-Pumps are used to pre-treat a liquid stream prior to analysis. The pumps are capable of pumping highly aggressive chemical reagents from a remote location (outside of the instrument) and accurately dispense predetermined volumes of the reagents directly into the main liquid stream.

This eliminates the need for an intermediate mixing step inside the instrument.

Micro-Pumps can be used in either continuous or intermittent mode depending on the demands of the instrument.

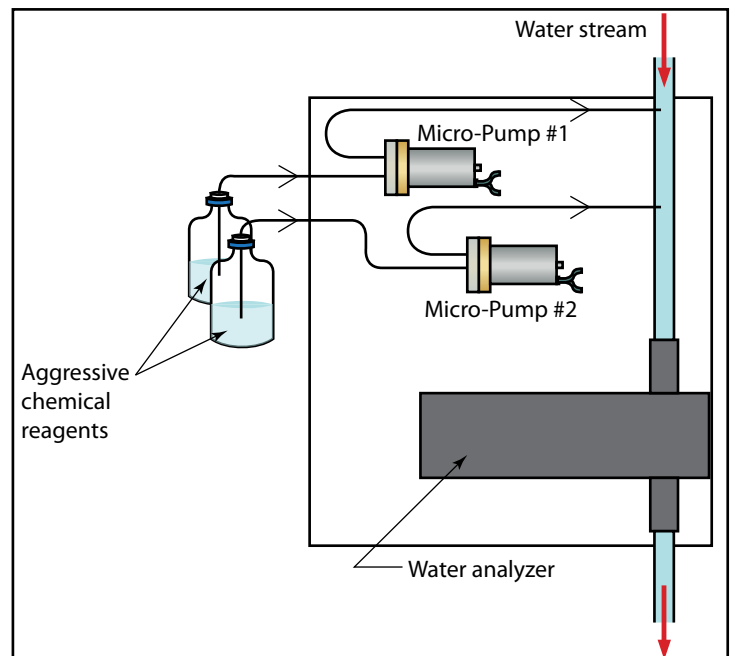

Sterilizing application

Sterilizing solution can be of a very high purity which almost always translates to additional expense. In this application a Bio-Chem Fluidics Micro-Pump takes small amounts of the sterilizing liquid from a reservoir and dispenses very accurate "drips" onto a heating panel inside a sterilizing chamber. When the liquid hits the panel, it instantly vaporizes forming a "sterilizing vapor" inside the chamber. The vapor is very efficient at sterilizing the internals of complicated components.

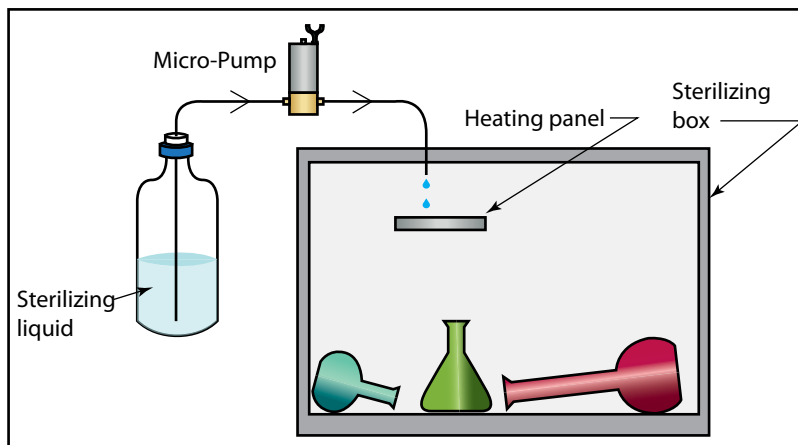

The Micro-Pumps provide highly repeatable and consistent delivery of the sterilizing fluid into the chamber. This safe and cost effective method of pumping high purity liquids has proved very successful.

Micro-Pump Selection Guide

- Select pump style; either Ported or Manifold mount and work from the appropriate table:
 - Ported for direct connection with $\frac{1}{4}$ "-28 fittings ($\frac{5}{16}$ "-24 for 150SP)
 - Manifold mount for use with manifolds (see page 13)

Then:

- Locate the volumetric characteristics that best suit your needs
- Choose your preferred body material depending on the level of chemical inertness you require
- Turn to the pages indicated to see full details and ordering information for each pump.

	Volumetric output		Body Material			
	Discrete Dispense Vol (μ l)	Max flow rate (ml/min)	PTFE	PPS	PEEK™	POM
Ported	20	2.4				
	30	3.6	130SP (pg. 7)	120SP (pg. 5)	120SP (pg. 5)	130SP (pg. 7)
	40	4.8				
	50	6.0				
	60	7.2				
	100	9.6				
	125	12.0				
	150	14.4				
	175	16.8		150SP (pg. 9)	150SP (pg. 9)	
	200	19.2				
	225	21.6				
250	24.0					

	Volumetric output		Body Material			
	Discrete Dispense Vol (μ l)	Max flow rate (ml/min)	PTFE	PPS	PEEK™	POM
Manifold mounted	20	2.4				
	30	3.6	139SP (pg. 11)		139SP (pg. 11)	139SP (pg. 11)
	40	4.8				
	50	6.0				
	60	7.2				

Polymers referenced in this brochure:

EPDM = ethylene-propylene-diene
 ETFE = ethylene tetrafluoroethylene
 FEP = fluorinated ethylene propylene
 FKM = fluorinated elastomer
 FFKM = perfluoro elastomer
 PEEK™ = polyetheretherketone
 POM = polyoxymethylene (Acetal resin)
 PPS = polyphenylene sulfide
 PTFE = polytetrafluoroethylene.

120SP SERIES MICRO-PUMP

For precise dispensing between 20 and 60µl and flow rates up to 7.2 ml/min

- Self-priming
- 20-60µl discrete dispense volumes
- Up to 7.2 ml/min maximum flow rate
- 1/4"-28 UNF threaded ports

The 120SP series Micro-Pumps are solenoid operated, with the operating mechanism isolated from the flow path by a diaphragm. Check valves situated at the inlet and outlet of the pump control the direction of flow. The combination of materials for each component can be selected to best suit your specific application.

Materials available for the wetted parts are:

- Body materials: PPS, PEEK™
- Diaphragm materials: PTFE, EPDM
- Check valve materials: EPDM, FKM, FFKM

120SP series options

NOTE: For 24 VDC, replace 120SP12 with 120SP24 in any of the part numbers listed.

PART NO.	DISPENSE VOL (µL)	BODY MATERIAL	DIAPHRAGM MATERIAL	CHECK VALVE MATERIAL
12 VDC; 20µl dispense				
120SP1220-4EE	20	PPS	EPDM	EPDM
120SP1220-4TV	20	PPS	PTFE	FKM
120SP1220-4TP	20	PPS	PTFE	FFKM
120SP1220-5EE	20	PEEK™	EPDM	EPDM
120SP1220-5TV	20	PEEK™	PTFE	FKM
120SP1220-5TP	20	PEEK™	PTFE	FFKM
12 VDC; 30µl dispense				
120SP1230-4EE	30	PPS	EPDM	EPDM
120SP1230-4TV	30	PPS	PTFE	FKM
120SP1230-4TP	30	PPS	PTFE	FFKM
120SP1230-5EE	30	PEEK™	EPDM	EPDM
120SP1230-5TV	30	PEEK™	PTFE	FKM
120SP1230-5TP	30	PEEK™	PTFE	FFKM

ARRANGEMENT

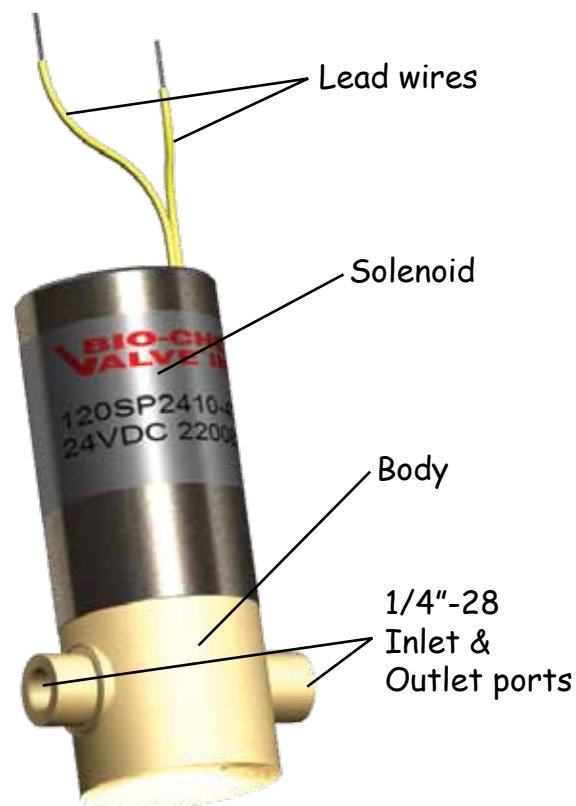

PART NO.	DISPENSE VOL (µL)	BODY MATERIAL	DIAPHRAGM MATERIAL	CHECK VALVE MATERIAL
12 VDC; 40µl dispense				
120SP1240-4EE	40	PPS	EPDM	EPDM
120SP1240-4TV	40	PPS	PTFE	FKM
120SP1240-4TP	40	PPS	PTFE	FFKM
120SP1240-5EE	40	PEEK™	EPDM	EPDM
120SP1240-5TV	40	PEEK™	PTFE	FKM
120SP1240-5TP	40	PEEK™	PTFE	FFKM
12 VDC; 50µl dispense				
120SP1250-4EE	50	PPS	EPDM	EPDM
120SP1250-4TV	50	PPS	PTFE	FKM
120SP1250-4TP	50	PPS	PTFE	FFKM
120SP1250-5EE	50	PEEK™	EPDM	EPDM
120SP1250-5TV	50	PEEK™	PTFE	FKM
120SP1250-5TP	50	PEEK™	PTFE	FFKM
12 VDC; 60µl dispense (Note: EPDM diaphragm for all 60 µl options)				
120SP1260-4EE	60	PPS	EPDM	EPDM
120SP1260-5EE	60	PEEK™	EPDM	EPDM

INSTALLATION DRAWING

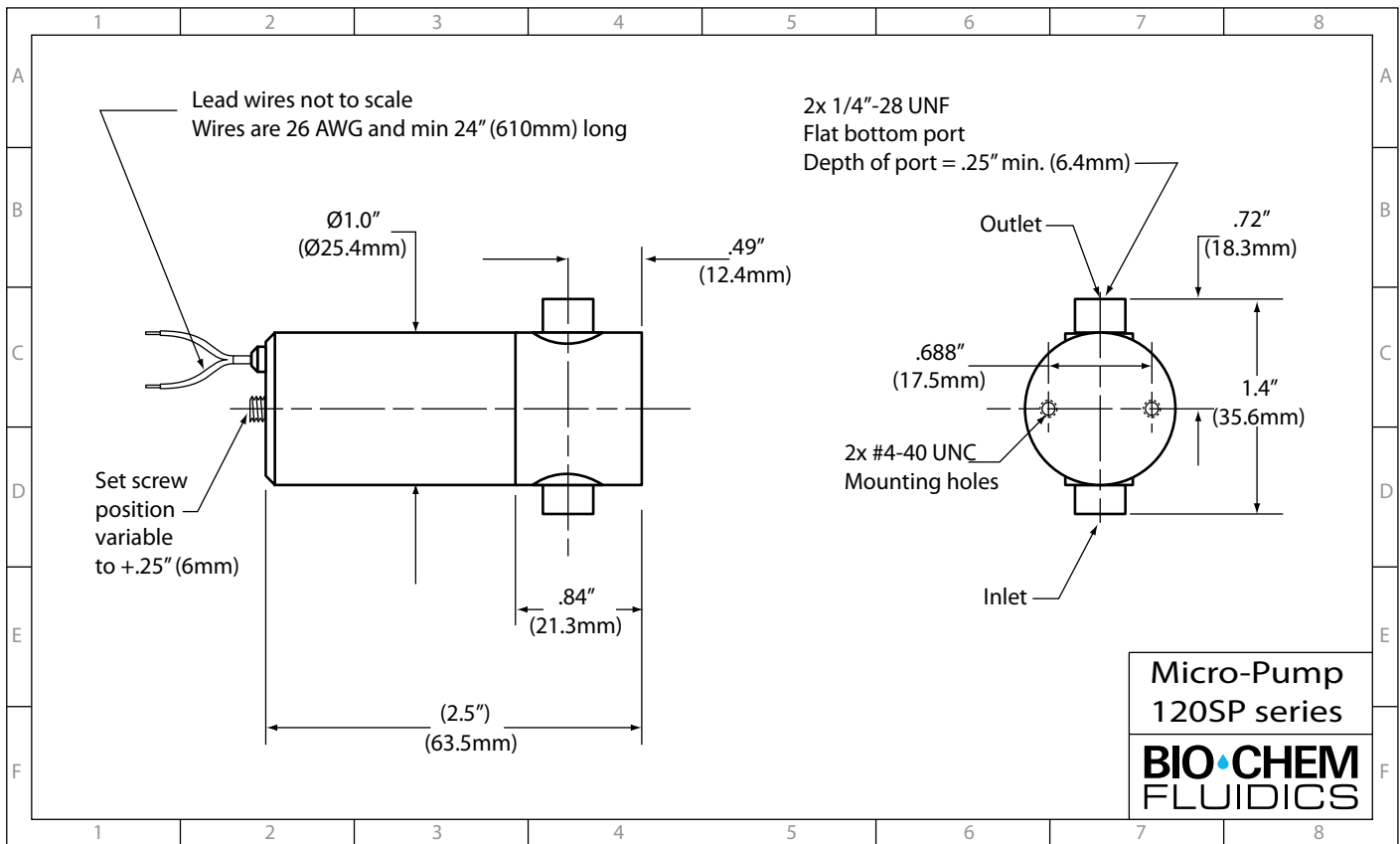

SPECIFICATIONS

120SP Fluid Data					
Dispense Volume (µl)	20	30	40	50	60
Set-point accuracy	+/- 10%	+/- 10%	+/- 10%	+/- 10%	+/- 10%
Repeatability	+/- 5%	+/- 5%	+/- 5%	+/- 5%	+/- 5%
Max flow rate (µl/min)	2400	3600	4800	6000	7200
Internal vol (µl)	105	105	105	105	105

120SP Electrical Data				120SP Cycle Rates		
Voltage	Power @70°F (21°C)	Current @70°F (21°C)	Effective continuous power @ max cycle rate	Fixed "on" time	Min "off" time	Max cycle rate
12 VDC	4.0 Watts	0.32 amps	1.2 Watts	150 msec	350 msec	2.0 Hz
24 VDC	4.0 Watts	0.16 amps	1.2 Watts			

Recommended tubing for 120SP Inlet & outlet, 1/32" (0.80mm) ID, hardwall tubing

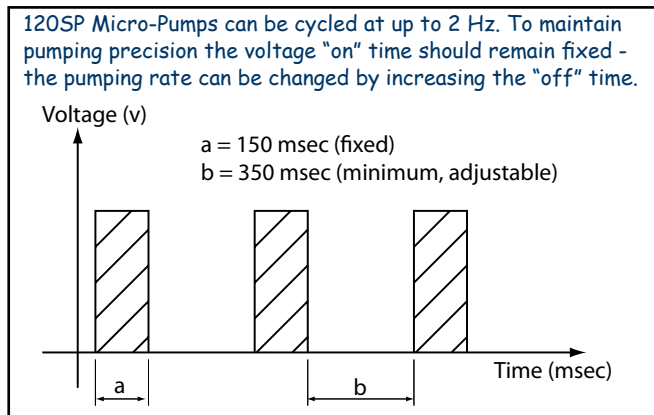

130SP SERIES MICRO-PUMP

For precise dispensing between 20 and 60µl and flow rates up to 7.2 ml/min

- Self-priming
- 20-60µl discrete dispense volumes
- Up to 7.2 ml/min maximum flow rate
- ¼"-28 UNF threaded ports
- Most inert body material for harshest applications

The 130SP series Micro-Pumps are solenoid operated, with the operating mechanism isolated from the flow path by a diaphragm. Check valves situated at the inlet and outlet of the pump control the direction of flow. The combination of materials for each component can be selected to best suit your specific application.

Materials available for the wetted parts are:

- Body materials: PTFE, POM
- Diaphragm materials: PTFE, EPDM
- Check valve materials: EPDM, FKM, FFKM

130SP series options

NOTE: For 24 VDC, replace 130SP12 with 130SP24 in any of the part numbers listed.

PART NO.	DISPENSE VOL (µL)	BODY MATERIAL	DIAPHRAGM MATERIAL	CHECK VALVE MATERIAL
12 VDC; 20µl dispense				
130SP1220-1TP	20	PTFE	PTFE	FFKM
130SP1220-6TV	20	POM	PTFE	FKM
130SP1220-6EE	20	POM	EPDM	EPDM
12 VDC; 30µl dispense				
130SP1230-1TP	30	PTFE	PTFE	FFKM
130SP1230-6TV	30	POM	PTFE	FKM
130SP1230-6EE	30	POM	EPDM	EPDM
12 VDC; 40µl dispense				
130SP1240-1TP	40	PTFE	PTFE	FFKM
130SP1240-6TV	40	POM	PTFE	FKM
130SP1240-6EE	40	POM	EPDM	EPDM
12 VDC; 50µl dispense				
130SP1250-1TP	50	PTFE	PTFE	FFKM
130SP1250-6TV	50	POM	PTFE	FKM
130SP1250-6EE	50	POM	EPDM	EPDM
12 VDC; 60µl dispense				
130SP1260-6EE	60	POM	EPDM	EPDM

ARRANGEMENT

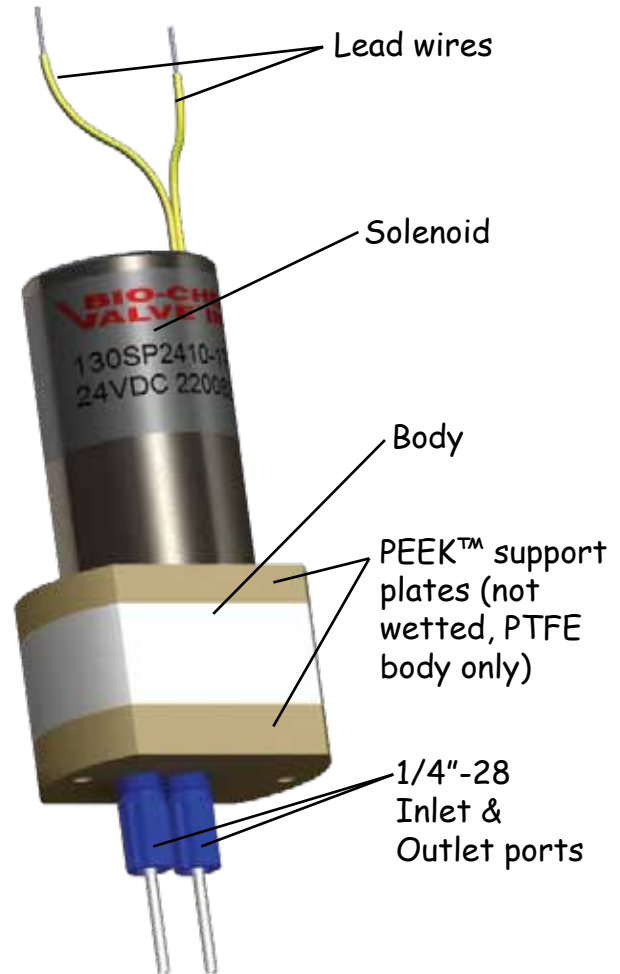

INSTALLATION DRAWING

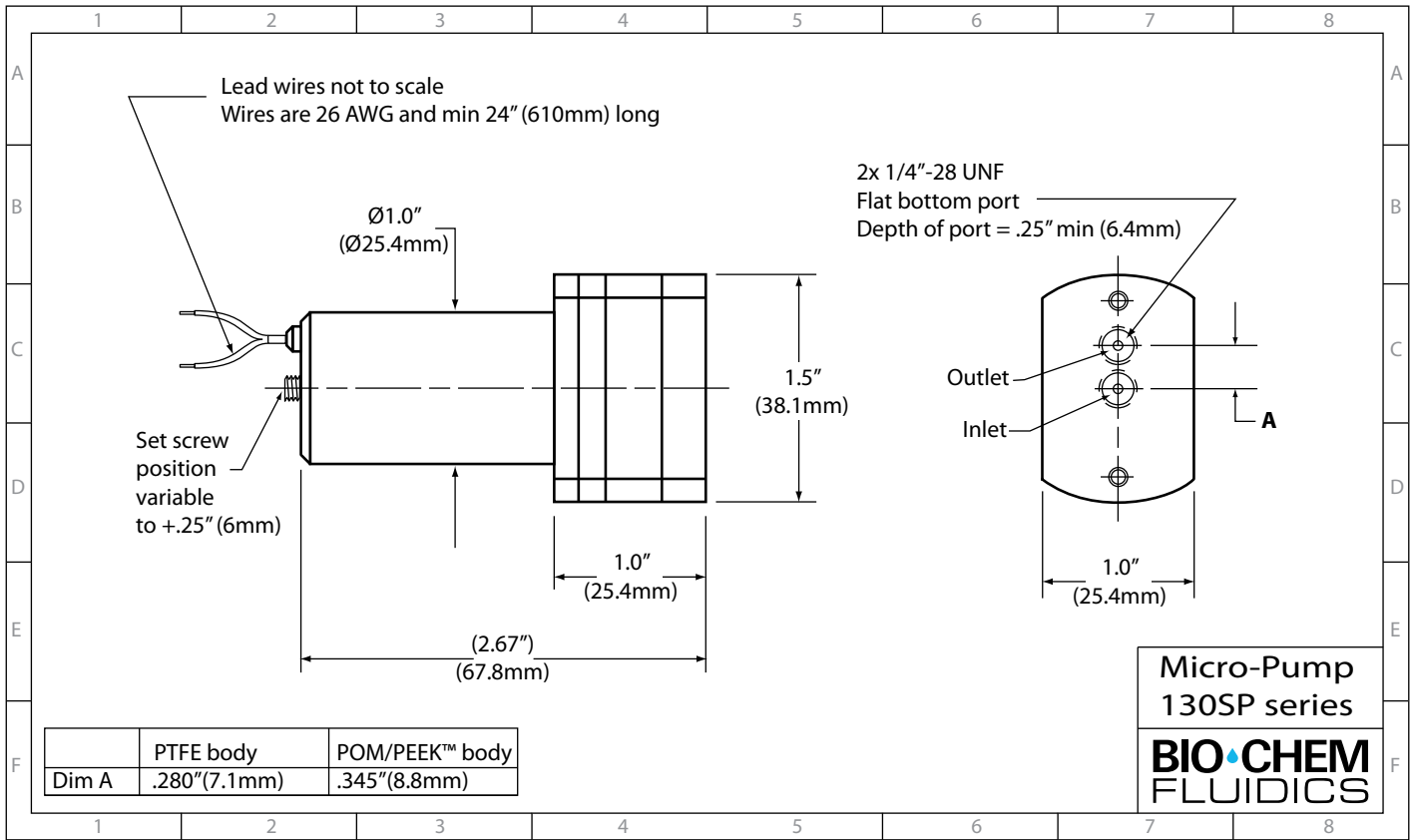

SPECIFICATIONS

130SP Volumetric Data					
Dispense Volume (µl)	20	30	40	50	60
Set-point accuracy	+/- 10%	+/- 10%	+/- 10%	+/- 10%	+/- 10%
Repeatability	+/- 5%	+/- 5%	+/- 5%	+/- 5%	+/- 5%
Max flow rate (µl/min)	2400	3600	4800	6000	7200
Internal vol (µl)	105	105	105	105	105

130SP Electrical Data				130SP Cycle Rates		
Voltage	Power @70°F (21°C)	Current @70°F (21°C)	Effective continuous power @ max cycle rate	Fixed "on" time	Min "off" time	Max cycle rate
12 VDC	4.0 Watts	0.32 amps	1.2 Watts	150 msec	350 msec	2.0 Hz
24 VDC	4.0 Watts	0.16 amps	1.2 Watts			

Recommended tubing for 130SP
Inlet & outlet, 1/32" (0.80mm) ID, hardwall tubing

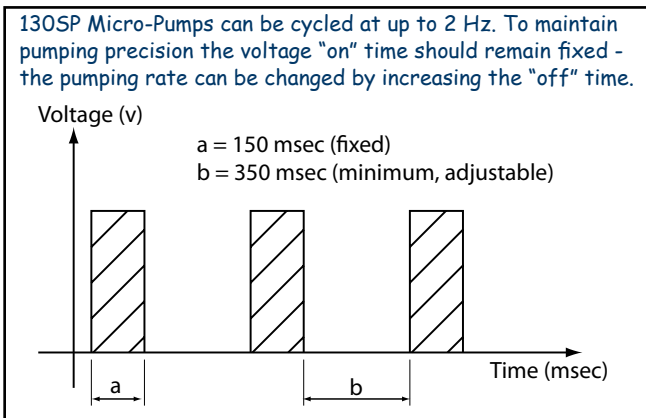

150SP SERIES MICRO-PUMP

For precise dispensing between 100 and 250µl and flow rates up to 24 ml/min

- Self-priming
- 100-250µl discrete dispense volumes
- Up to 24 ml/min maximum flow rate
- 5/16"-24 UNF threaded ports

The 150SP series Micro-Pumps are solenoid operated, with the operating mechanism isolated from the flow path by a diaphragm. Check valves situated at the inlet and outlet of the pump control the direction of flow. The combination of materials for each component can be selected to best suit your specific application.

Materials available for the wetted parts are:

- Body materials: PPS, PEEK™
- Diaphragm materials: EPDM
- Check valve materials: EPDM

150SP series options

NOTE: For 24 VDC, replace 150SP12 with 150SP24 in any of the part numbers listed.

PART NO.	DISPENSE VOL (µL)	BODY MATERIAL	DIAPHRAGM MATERIAL	CHECK VALVE MATERIAL
12 VDC; 100µl dispense				
150SP12100-4EE	100	PPS	EPDM	EPDM
150SP12100-5EE	100	PEEK™	EPDM	EPDM
12 VDC; 125µl dispense				
150SP12125-4EE	125	PPS	EPDM	EPDM
150SP12125-5EE	125	PEEK™	EPDM	EPDM
12 VDC; 150µl dispense				
150SP12150-4EE	150	PPS	EPDM	EPDM
150SP12150-5EE	150	PEEK™	EPDM	EPDM
12 VDC; 175µl dispense				
150SP12175-4EE	175	PPS	EPDM	EPDM
150SP12175-5EE	175	PEEK™	EPDM	EPDM
12 VDC; 200µl dispense				
150SP12200-4EE	200	PPS	EPDM	EPDM
150SP12200-5EE	200	PEEK™	EPDM	EPDM
12 VDC; 225µl dispense				
150SP12225-4EE	225	PPS	EPDM	EPDM
150SP12225-5EE	225	PEEK™	EPDM	EPDM
12 VDC; 250µl dispense				
150SP12250-4EE	250	PPS	EPDM	EPDM
150SP12250-5EE	250	PEEK™	EPDM	EPDM

ARRANGEMENT



INSTALLATION DRAWING

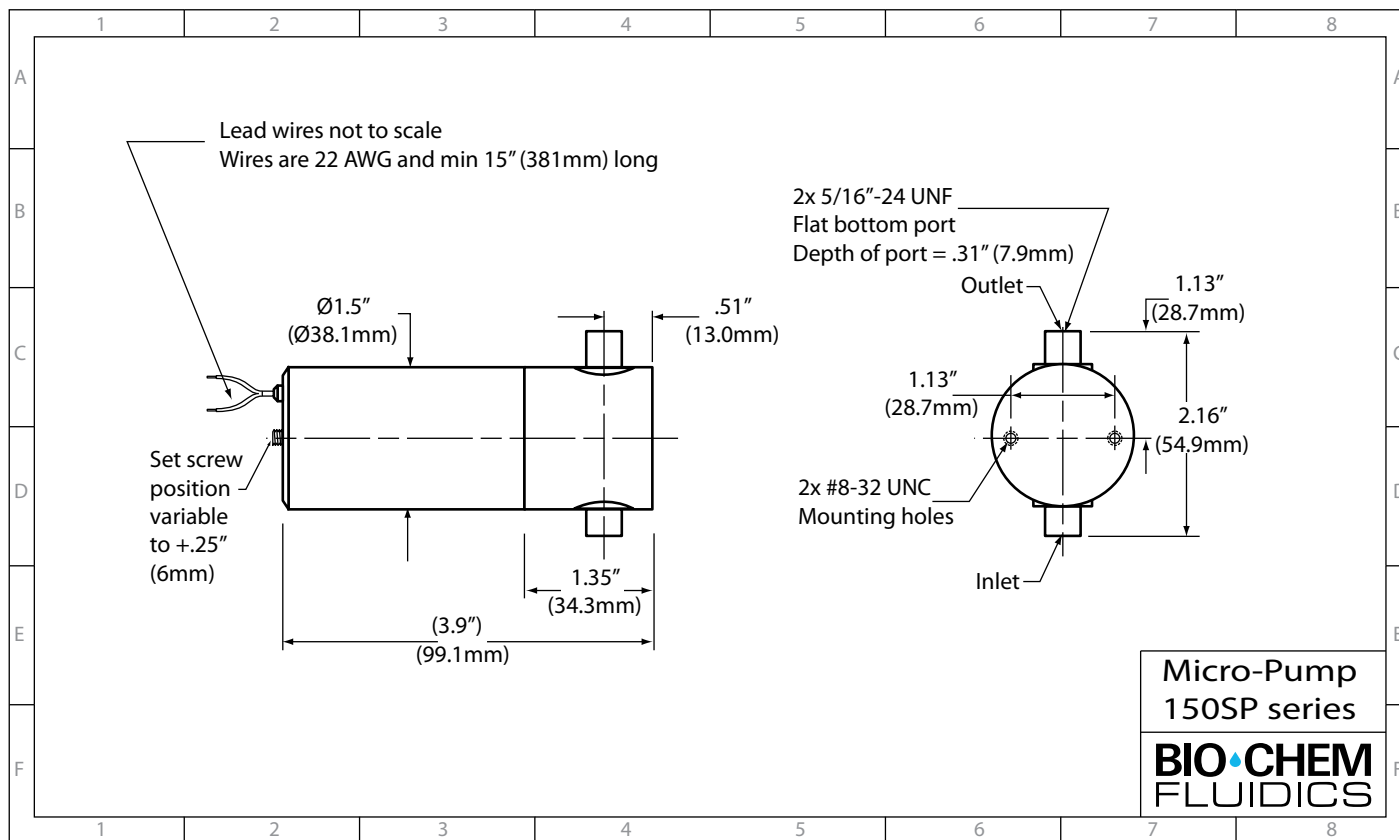

SPECIFICATIONS

150SP Fluid Data

	100	125	150	175	200	225	250
Dispense Volume (μl)	100	125	150	175	200	225	250
Set-point accuracy	$\pm 10\%$	$\pm 10\%$	$\pm 10\%$	$\pm 10\%$	$\pm 10\%$	$\pm 10\%$	$\pm 10\%$
Repeatability	$\pm 5\%$	$\pm 5\%$	$\pm 5\%$	$\pm 5\%$	$\pm 5\%$	$\pm 5\%$	$\pm 5\%$
Max flow rate ($\mu\text{l}/\text{min}$)	9600	12000	14400	16800	19200	21600	24000
Internal vol (μl)	710	710	710	710	710	710	710

150SP Electrical Data

Voltage	Power @70°F (21°C)	Current @70°F (21°C)	Effective continuous power @ max cycle rate	150SP Cycle Rates		
				Fixed "on" time	Min "off" time	Max cycle rate
12 VDC	8.0 Watts	0.66 amps	3.2 Watts	200 msec	400 msec	1.6 Hz
24 VDC	8.0 Watts	0.33 amps	3.2 Watts			

Recommended tubing for 150SP

Inlet & outlet, 1/8" (3.2mm) ID, hardwall tubing

150SP Micro-Pumps can be cycled at up to 1.6 Hz. To maintain pumping precision the voltage "on" time should remain fixed - the pumping rate can be changed by increasing the "off" time.

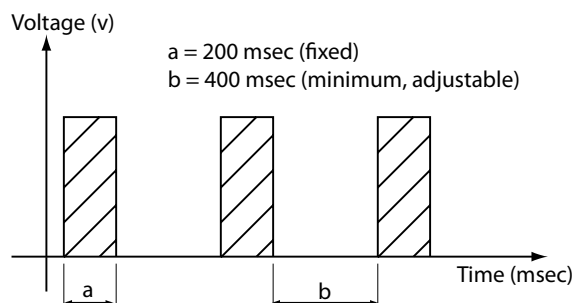

139SP SERIES MICRO-PUMP

For precise dispensing between 20 and 60µl and flow rates up to 7.2 ml/min in a manifold mountable design

- Self-priming
- 20-60µl discrete dispense volumes
- Up to 7.2 ml/min maximum flow rate
- Manifold mountable

This sibling to the 130SP Micro-Pump duplicates the performance characteristics but is supplied ready for mounting in your manifold. *Please contact us if you would like us to supply the manifold (see page 13).* Materials available for the wetted parts are:

- Body materials: PTFE, POM, PEEK™
- Diaphragm materials: PTFE, EPDM
- Check valve materials: EPDM, FKM, FFKM

139SP series options

NOTE: For 24 VDC, replace 139SP12 with 139SP24 in any of the part numbers listed.

PART NO.	DISPENSE VOL (µL)	BODY MATERIAL	DIAPHRAGM MATERIAL	CHECK VALVE MATERIAL
12 VDC; 20µl dispense				
139SP1220-1TP	20	PTFE	PTFE	FFKM
139SP1220-5TP	20	PEEK™	PTFE	FFKM
139SP1220-5TV	20	PEEK™	PTFE	FKM
139SP1220-5TE	20	PEEK™	PTFE	EPDM
139SP1220-6TV	20	POM	PTFE	FKM
139SP1220-6EE	20	POM	EPDM	EPDM

PART NO.	DISPENSE VOL (µL)	BODY MATERIAL	DIAPHRAGM MATERIAL	CHECK VALVE MATERIAL
12 VDC; 30µl dispense				
139SP1230-1TP	30	PTFE	PTFE	FFKM
139SP1230-5TP	30	PEEK™	PTFE	FFKM
139SP1230-5TV	30	PEEK™	PTFE	FKM
139SP1230-5TE	30	PEEK™	PTFE	EPDM
139SP1230-6TV	30	POM	PTFE	FKM
139SP1230-6EE	30	POM	EPDM	EPDM

ARRANGEMENT

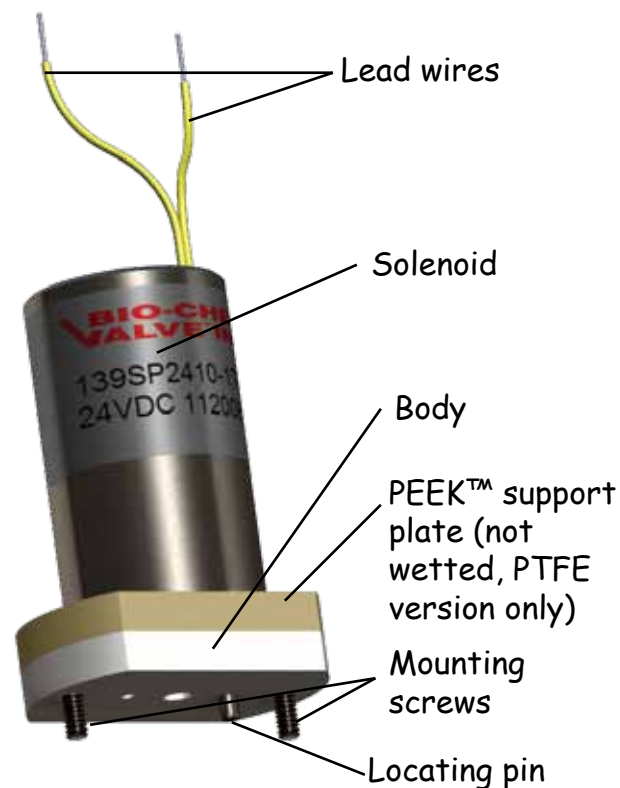

PART NO.	DISPENSE VOL (µL)	BODY MATERIAL	DIAPHRAGM MATERIAL	CHECK VALVE MATERIAL
12 VDC; 40µl dispense				
139SP1240-1TP	40	PTFE	PTFE	FFKM
139SP1240-5TP	40	PEEK™	PTFE	FFKM
139SP1240-5TV	40	PEEK™	PTFE	FKM
139SP1240-5TE	40	PEEK™	PTFE	EPDM
139SP1240-6TV	40	POM	PTFE	FKM
139SP1240-6EE	40	POM	EPDM	EPDM

PART NO.	DISPENSE VOL (µL)	BODY MATERIAL	DIAPHRAGM MATERIAL	CHECK VALVE MATERIAL
12 VDC; 50µl dispense				
139SP1250-1TP	50	PTFE	PTFE	FFKM
139SP1250-5TP	50	PEEK™	PTFE	FFKM
139SP1250-5TV	50	PEEK™	PTFE	FKM
139SP1250-5TE	50	PEEK™	PTFE	EPDM
139SP1250-6TV	50	POM	PTFE	FKM
139SP1250-6EE	50	POM	EPDM	EPDM

PART NO.	DISPENSE VOL (µL)	BODY MATERIAL	DIAPHRAGM MATERIAL	CHECK VALVE MATERIAL
12 VDC; 60µl dispense				
139SP1260-6EE	60	POM	EPDM	EPDM

SPECIFICATIONS

The 139SP has the same specifications as the 130SP (see page 7)

INSTALLATION DRAWING

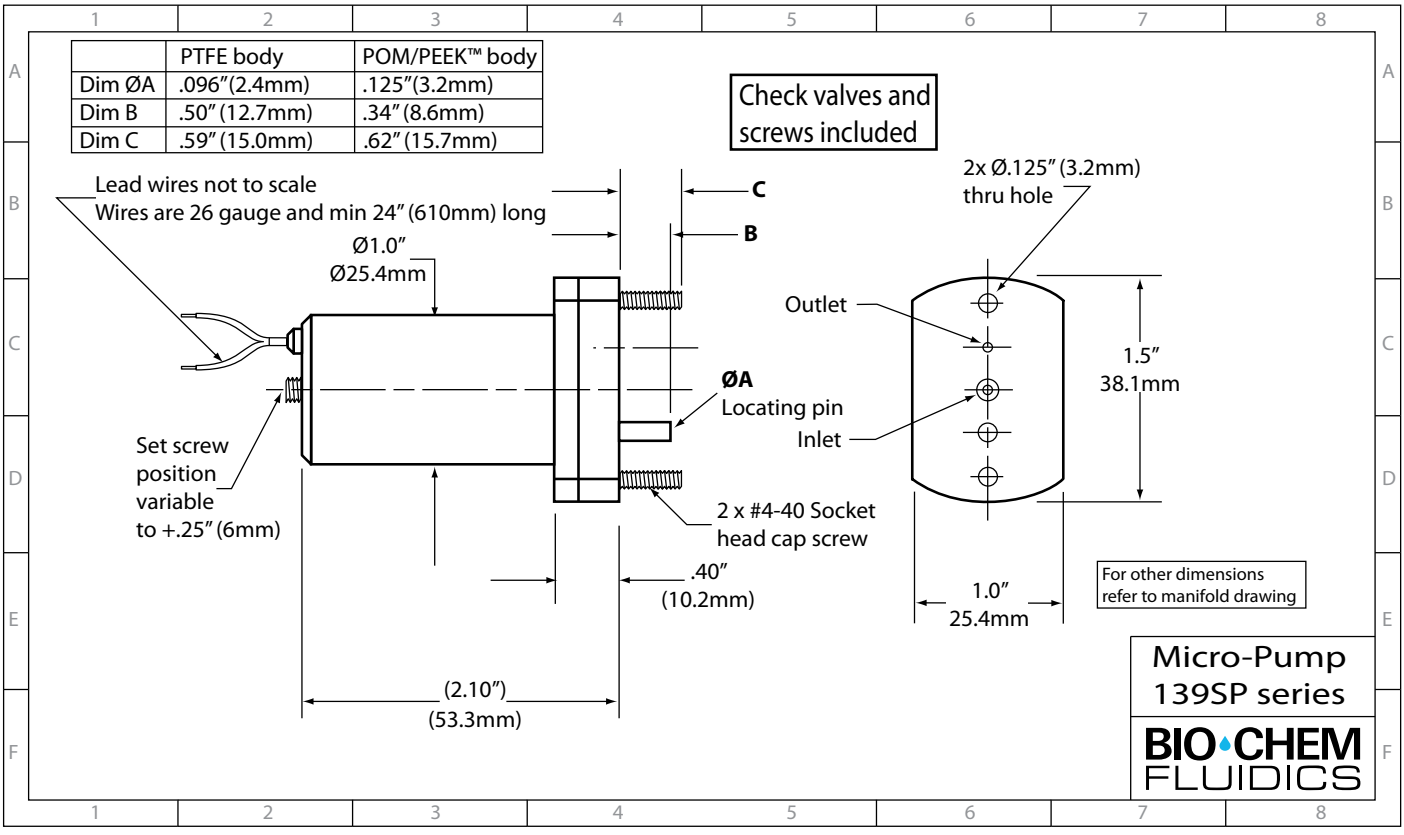

MANIFOLD INTERFACE DRAWING

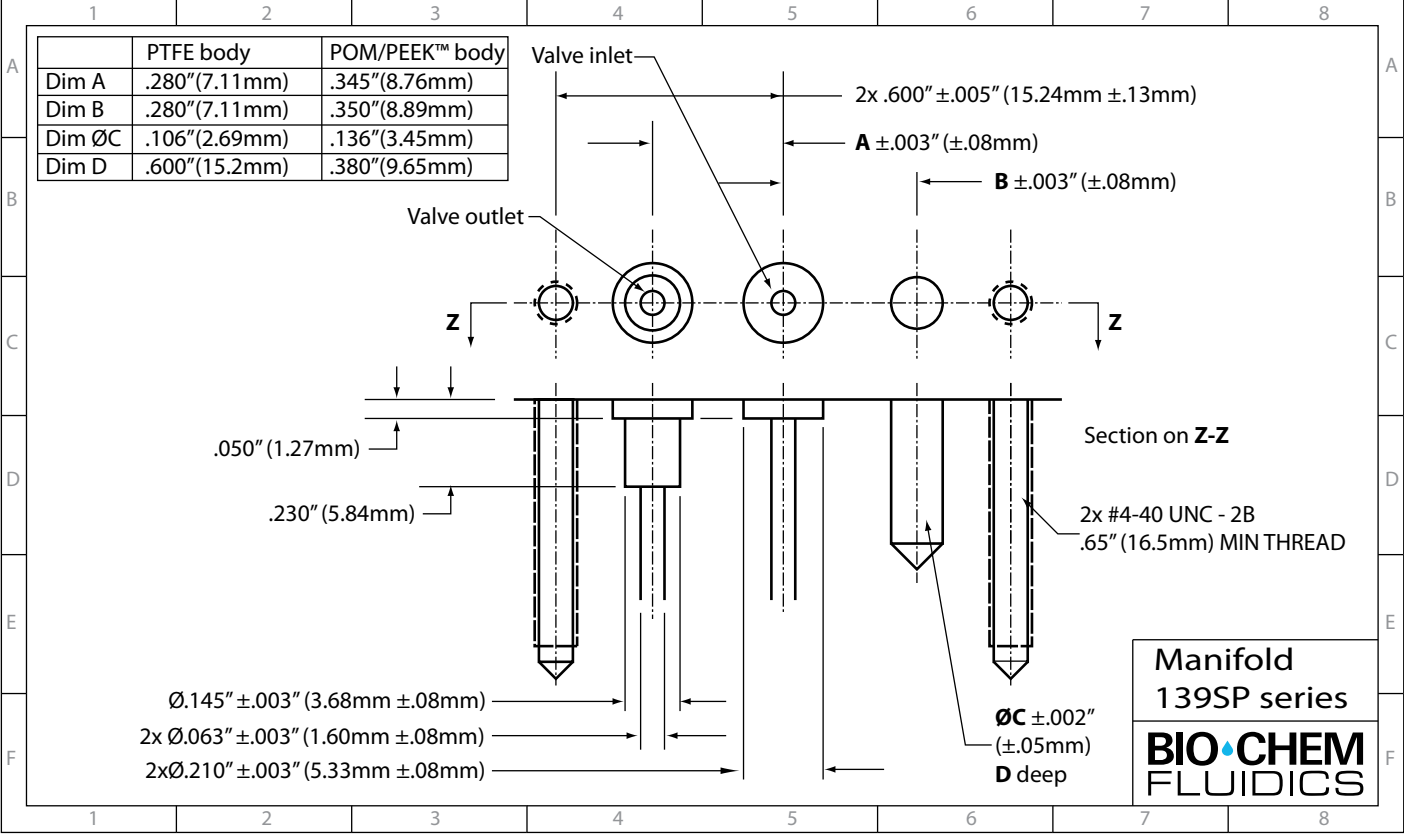

MANIFOLDS



Custom manifold for (1) 139SP Micro-Pump (shown) and (3) isolation valves (not shown). Blue lines indicate the fluid path; the red dots are ruby balls used as plugs.

Custom-built manifolds are used to organize multiple Micro-Pumps and other Fluid Control Devices such as Isolation Valves into an efficient, pre-assembled, space-saving module that is designed to meet your specific flow needs. Manifolds can range from simple blocks for two devices to complex shapes with intricate flow paths for many devices. Bio-Chem Fluidics has produced complex manifolds for as many as 84 Micro-Pumps on a single block.

Features:

- Reduction of internal equipment space requirements.
- Allows for the combining of valves, tubing, pumps and connectors into a single, pre-assembled component.
- Elimination of unsightly and unmanageable wiring and tubing.
- Helps to reduce inventory.
- Reduces production time and costs associated with testing, handling and assembling multiple components.
- Materials of construction to suit fluid characteristics including, but not limited to; PTFE, POM, PEEK™, acrylic and PPS.

Please contact your local Bio-Chem Fluidics facility to discuss your manifold requirements with one of our engineers.



Custom manifold for (2) 139SP Micro-Pumps (not shown).

MOUNTING OPTIONS

Bio-Chem Valve™ Solenoid Operated Micro-Pumps can be installed into your equipment with a variety of mounting options including mounting clips, rings and flanges. Some of the pumps can be mounted directly via mounting holes that are drilled into the pump body. For more details refer to the "Mounting Accessories & Options" spec sheet.



MU-Series Mounting Flange

- Constructed from sturdy, glass-filled Polypropylene
- Spring steel retainer ring and set screw ensure a secure fit
- Surface withstands alcohol, bleaches and other common cleaning agents

- Can be bulkhead mounted, inside or outside
- Screw hole orientation relative to tubing can be adjusted to fit available system space



MC-Series Mounting Clip

- Constructed from Spring Steel
- Simple construction - no tools required to secure pump into position
- Holds pump securely inside instrument



MR-Series Mounting Ring

- Constructed from Aluminum
- Tightening screw secures ring firmly to pump but can be loosened for re-positioning
- Can be bulkhead mounted, inside or outside

- Screw hole orientation relative to tubing can be adjusted to fit available system space



Integral Mounting Holes

- Threaded mounting holes in the base of the pump provide a more permanent way to mount directly to a plate or base
- Mounting holes are standard on 120SP and 150SP Micro-Pumps

MICRO-PUMP TECH TIPS

OPERATING PARAMETERS & INSTALLATION TIPS

Output volume and accuracy: A number of factors influence the output volume of our pumps. In our factory the pump's setpoint is determined using the following test conditions:

- Fluid: De-ionized water at 70°F/21°C
- Fittings: Omni-Lok™ 1/4"-28 inverted cone fittings for the 120SP and 130SP pump families and 3/16"-24 inverted cone fittings for the 150SP pumps.
- Tubing: PTFE tubing with the following dimensions:
 - 120SP and 130SP pump families: Internal diameter of 1/32", 3"/8cm ≤ tubing length ≤ 14"/35cm.
 - 150SP pumps: Internal diameter of 1/8" on the inlet and 1/16" on the outlet, 3"/8cm ≤ tubing length ≤ 10"/25cm
- Pressure: Negligible pressure on both the inlet and outlet ports.
- Cycle rates:
 - 120SP & 130SP pump families: 250ms on / 350ms off
 - 150SP pump family: 250ms on / 750ms off
- No air or gas bubbles in the line once the priming process is complete. (See the Priming section on right)

If your application parameters deviate significantly from the above, you may experience dispense rates that are different from the setpoint. In that case, please contact Bio-Chem Fluidics to discuss your application and we will make appropriate adjustments for you.

Pressure limits: Although Micro-Pumps are capable of producing outlet pressures of up to 5 psi (0.35 bar) while a dispense is taking place, for optimal dispense accuracy, the pressure on both the inlet and the outlet side of the pump should be kept between ± 0.5 psi (0.035 bar), equivalent to a head of ± 12" (300mm) water.

During the pump's up-stroke, suction is created on the inlet. Positive pressure is generated at the outlet during the down-stroke. When the pump is not actuated, it will shut-off flow as long as the pressure on the inlet does not exceed the maximum holding pressure. To ensure correct operation, pressure on the inlet side should never exceed 2 psi (0.14 bar) even when the pump is in the closed position. The check valves in the pump prevent fluid from flowing against the intended flow direction.

Orientation: Pumps should be installed with the solenoid portion of the pump pointing upwards, downwards or in a horizontal position with the outlet on top. This ensures that any air in the system will be evacuated quickly and also minimizes the effects of a pressure head acting to keep the check elements open when they should be closed.

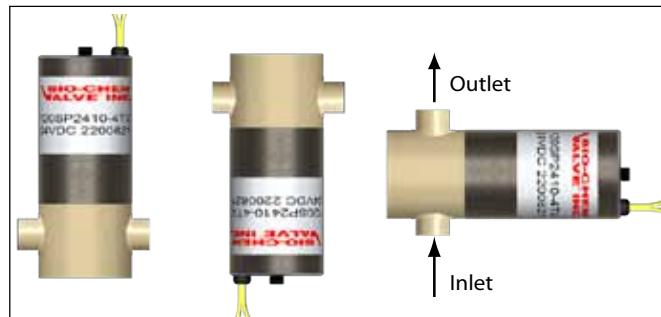

Preferred mounting positions

Lead Wires: As a standard all lead wires are PTFE coated. Lead wires are provided with stripped ends for easy wiring into your control system - refer to drawings on product pages for more details. Different lengths and terminal connectors can be provided - refer to customization notes below.

Priming: Micro-Pumps must be fully primed prior to operation to ensure that all air is removed from the pump cavity. Priming is achieved by cycling the pump until no air bubbles are seen in the dispense. This normally takes 30-60 seconds. Excessive air bubbles in the dispense are generally caused by air leaks due to loose fittings - check all the fittings in the system and tighten accordingly.

CUSTOMIZED SOLUTIONS

We understand that many applications require customized solutions. Our design and prototyping expertise enables us to offer simple modifications of standard products as well as completely customized designs. Many of the Micro-Pumps we sell are customized to one extent or another. Customizable options include (but are not limited to):

- Materials of construction
- Dispense volume
- Mounting options
- Tagging / labeling
- Length and/or style of connecting leads
- Electrical terminations
- Custom manifolds

We look forward to working with you to meet your design engineering objectives!

THE BIO-CHEM FLUIDICS BRAND FAMILY

Bio-Chem Fluidics is dedicated to providing instrument manufacturers and laboratories with the industry's best choice of inert, miniature fluid handling components.

Under the Bio-Chem Valve™ brand name we offer a complete fluid system solution for a wide range of industries including analytical chemistry, clinical diagnostics and medical device manufacturers as well as the scientific community.

BIO-CHEM FLUIDICS

INERT SOLENOID VALVES AND PUMPS, ELECTRIC ROTARY VALVES

MICRO-PUMPS



ISOLATION VALVES



FLOW SELECTION
VALVES

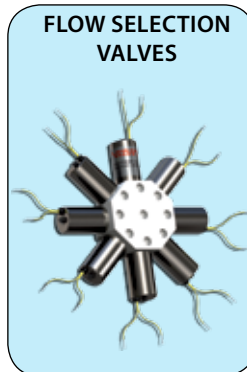

PINCH VALVES



ELECTRIC ROTARY
VALVES



MANIFOLD
ASSEMBLIES



ACCESSORIES



CUSTOMIZATION
SERVICES

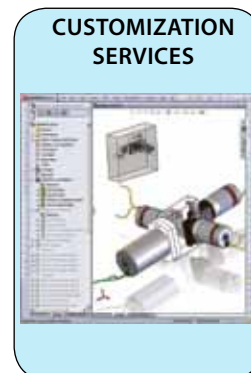

Trademarks

PEEK™ is a registered trademark of Victrex plc.

Bio-Chem Valve™ is a trademark of Bio-Chem Fluidics Inc.

BIO·CHEM
FLUIDICS

www.biochemfluidics.com

Bio-Chem Fluidics Inc
85 Fulton Street, Boonton NJ 07005 USA
t: (973) 263 3001 f: 973 263 2880 e: sales.us@biochemfluidics.com

Bio-Chem Fluidics Technology (Shanghai) Co. Ltd
South Metropolis Industrial Park, Jindu Road, Minhang District, Shanghai, PRC 201108
t: +86 21 61519058 f: +86 21 61519090